

# HD9

chassis 6x6

**66.38 / 66.42 / 66.44 / 66.48 / 66.54**

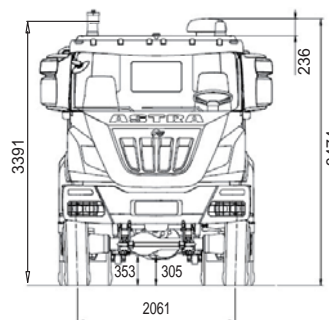
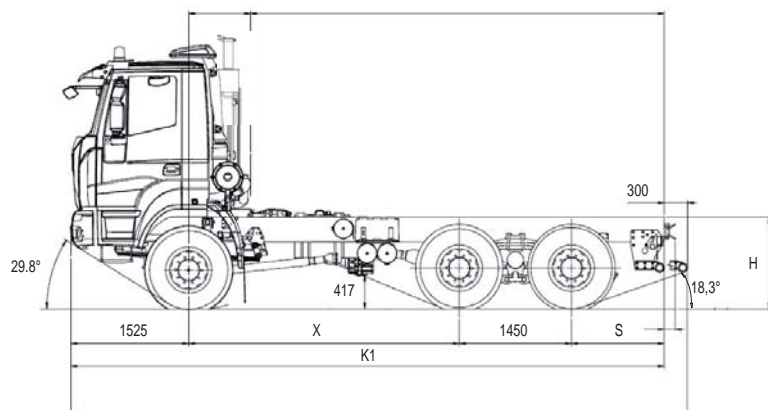

## DIMENSIONS (mm) short cab (Tyres 13R22,5 156/150G)

X	K1	M max (*)	S	H	
				unloaded	loaded
3500	7675	5350	1200	1252	1189
3800	7975	5650	1200		
4100	8275	5950	1200/1500/1900		
4500	8675	6350	1200/1900/2500		
4750	9625	7300	1900		
5100	9975	7650	1900		

(\*) M max.: indicative value to be confirmed by bodybuilder.



## WEIGHT (kg)

X	Distribution net weight (*)			Max. technical weight			
	1 <sup>st</sup> axle	2 <sup>nd</sup> +3 <sup>rd</sup> axle	Net weight	1 <sup>st</sup> axle	2 <sup>nd</sup> +3 <sup>rd</sup> axle	Gross Vehicle weight	Gross Combination weight
3500	5320	4835	10155	8000 8500(1) 9000(2) 10000 (3)	32000	40000 (2)	104000
3800	5355	4865	10220				
4100	5375	4915	10290				
4500	5400	4970	10370				
4750	5430	5000	10430				
5100	5470	5035	10505				

(\*)Weight including oil, fuel, spare wheel, driver Kg.75

(1) With tyres 1<sup>st</sup> axle 385/65R22,5160J or 365/85R20166G. Other tyres available, subject to the Astra technical office approval.

(2) HD9 66.48 and HD9 66.54 only at max speed 50 km/h. Michelin/Pirelli tyres. Higher speeds are allowed with load reductions subject to the Astra Technical office approval.

(3) 10,000 kg optional: see description on the following pages 10 t.



## ENGINES

CURSOR 13 turbo intercooler **euro 3** diesel injection/cycle with electronic unit injection pumps. Single block head, four valves per cylinder, light alloy pistons. Total displacement: 12.882 cm<sup>3</sup>. Bore for stroke: 135 x 150 mm. 6 in-line cylinders. Water cooling. Viscostatic cooling fan. Dry air filter with safety cartridge. Vertical muffler

	66.38	66.42	66.44	66.48	66.54*
Model	IVECO F3B	IVECO F3B	IVECO F3B	IVECO F3B	IVECO F3B
Max. power (EEC)	280 kW ( 380 HP)	309 kW (420 HP)	324 kW (440 HP)	353 kW (480 HP)	397 kW (540 HP)
Corresponding rpm	1.900		1.900		
Max. torque (EEC)	1.800 Nm (183 kgm)	1.900 Nm (194 kgm)	2.100 Nm (214 kgm)	2.200 Nm (224 kgm)	2.350 Nm (240 kgm)
Corresponding rpm	1.000-1.440				1.000-1.690
Turbine	WG Waste Gate		VGT variable geometry		

\*Requires additional engine radiator, for extremely hot climate (>42°C).



## GEARBOX

Manual gear with servoshift, 16 synchronised forward speeds + 2 reverse.

ZF 16 S 1820 TO: HD9 66.38

ZF 16 S 2220 TO: HD9 66.42/HD9 66.44

ZF 16 S 2520 TO: HD9 66.48/ HD9 66.54

On request:

ZF 16 S 1920 TD: HD9 66.38 and HD9 66.42

ZF 16 S 2320 TD: HD9 66.38/ HD9 66.42/ HD9 66.44/ HD9 66.48

ASTRONIC ZF 16AS2601 OD: HD9 66.44 / HD9 66.48 and HD9 66.54

Automatic gearbox ALLISON HD4700: HD9 66.44/HD9 66.48 and HD9 66.54 with wheelbase > 4100.

		Speed [kph] at maximum power (*)																		
		Gears																		
		1	2	3	4	5	6	7	8	9	10	11	12	13	14	15	16	RM	RM	
ZF16S1820TO - ZF16S2220TO ZF16S2520TO	Gear ratios	13.80	11.54	9.49	7.93	6.53	5.46	4.57	3.82	3.02	2.53	2.08	1.74	1.43	1.20	1.00	0.84	12.92	10.80	
	Rear axle ratio	1:3.793	9.0	10.8	13.1	15.7	19.1	22.8	27.3	32.6	41.3	49.2	59.9	71.6	87.1	103.8	124.6	148.3	9.6	11.5
		1:4.229	8.1	9.7	11.8	14.1	17.1	20.5	24.5	29.3	37.0	44.2	53.7	64.2	78.1	93.1	111.8	133.0	8.6	10.3
		1:5.009	6.8	8.2	9.9	11.9	14.4	17.3	20.6	27.4	31.2	37.3	45.4	54.2	66.0	78.6	94.4	112.3	7.3	8.7
		1:5.558	6.2	7.4	9.0	10.7	13.0	15.6	18.6	22.3	28.2	33.6	40.9	48.9	59.5	70.9	85.0	101.2	6.6	7.9
		1:6.095	5.6	6.7	8.2	9.8	11.9	14.2	17.0	20.3	25.7	30.6	37.3	44.6	54.2	64.6	77.5	92.3	6.0	7.2
1:6.588	5.2	6.2	7.6	9.0	11.0	13.1	15.7	18.8	23.8	28.4	34.5	41.2	50.2	59.8	71.7	85.4	5.6	6.6		

(\*) Max speed 90 km/h. Other speeds available, subject to the Astra technical office approval.



## P.T.O.

On request:

Gearbox	ZF16S1620TD	ZF16S1820TO ZF16S2220TO ZF16S2520TO	Max. torque	Application
P.T.O.	Ratio	Ratio	Nm.	
ZF NH/1b	0,77/0,91:1	0,91/1,09:1	1000	For tipping unit pumps, pumps for cranes, ecc..
ZF NH/1c	0,77/0,91:1	0,91/1,09:1	1000	For tipping unit pumps, unit pumps for concrete, pumps for cranes, ecc..
ZF NH/4c	0,98/1,17:1	1,17/1,40:1	430	For tipping unit pumps, ecc..
ZFN221/10bpl+N353/1c		1,75/2,09:1+0,91/1,09:1	560+600	double PTO for concrete pumps

ZF NMV1 221 Power take-off (ratio 1,55:1) max available torque 1300 Nm for concrete pumps (380 and 420HP excluded).



## CLUTCH

Single dry plate, diameter 17". Pull type engagement with diaphragm spring. Hydro-pneumatic power steering engagement control, with driven disc wear recovery slave cylinder.



## TRANSFER

Mechanical with two ratios. It consists of a series of helical spur gears, mounted on three propeller shafts, engaged with each other. Differential can be locked by pneumatic control.

Transmission ratio: 1:1 - 1:1,6

Front/rear torque distribution ratio: 1:4,0

Technical data and general specifications - validity to be checked according to each individual country.



## AXLES

### FRONT:

Steering cast iron type; with double reduction, central with bevel pinion-crown, lateral by means of epicyclical assembly in wheel hubs.

### On request:

Front axle simplex or duplex wedge type Kessler.

### REAR:

Two drive axles in tandem with double reduction, central by bevelled pair and final by epicyclical group in wheel hubs. The intermediate axle is fitted with distributor that distributes torque between the two axles Lockable differential with pneumatic control from driver seat. The tandem is anchored to the chassis by silent block mounted torque arms.

### On request:

Rear-axle ratio 1:3.793

Rear-axle ratio 1:4.229

Rear-axle ratio 1:5.009

Rear axle ratio 1:5.558

Rear-axle ratio 1:6.095

Rear-axle ratio 1:6.588

## 10t FRONT AXLE G.V.W. 10t

Front axle simplex or duplex wedge type Kessler and Gross Weight 10,000 Kg. Parabolic springs 5 leaves 24x90 mm.

Hydraulic power steering ZF 8099 with variable ratio 1:22.2/1:26.2. Tyres combination subject to approval of Astra Technical Office.

Axle ratio 1:6.33. Maximum speed 70 Km/h.



## SUSPENSIONS

### FRONT

Parabolic leaf springs with bushings, 4 leaves 24x90 mm, with shock absorbers and standard stabiliser.

### On request:

Reinforced conventional springs. 10 leaves 15x90 mm.

Reinforced parabolic springs, n° 5 leaves 24x90 mm.

### REAR

Parabolic springs, swivelling on central pin: 4 leaves 40x100 mm, supplemented by torque bars and stiffening brackets.

### On request:

Stabiliser bar on 2<sup>nd</sup> axle.

Stabiliser bar on 3<sup>rd</sup> axle.

Extra-reinforced conventional springs, 10 leaves 25x100 mm.



## CHASSIS

Special steel with high elasticity limit, two flat and parallel side members width 820 mm., C section 320x90x10mm, cross members riveted to the frame.

Steel front bumpers with headlamp protection grids, front manoeuvring hook, rear underrun bar, steel fuel tank capacity 300 litres.

### On request:

Rapid attachment for compressed air for tyres'inflation.

Rear underrun bar in set back position.

Extra long underrun bar for concrete mixer.

Rear manoeuvring hook.

Rear automatic towing hook.

Rubber mudguards on 2<sup>nd</sup> and 3<sup>rd</sup> axle.

Front bumper climbing step.



## STEERING

Hydraulic power steering ZF 8098 with variable ratio 1:22.2/1:26.2.

Steering linkage with self lubricating floating joints.

Height and inclination mechanical adjustable steering wheel.



## TYRES

### FRONT:

13R22,5 156/150 G Single tubeless

### REAR:

13R22,5 156/150 G Twin tubeless

Spare wheel on the chassis.

### Other Possible combinations:

TYRES	ASSEMBLY	
	FRONT	REAR
13 R 22,5 156/150G		
12 00 R 20 156/150G	S	D
315/80 R 22,5 156/150G		
365/85 R 20 164G	S	
13 R 22,5 156/150G		
12 00 R 20 156/150G		D
365/80 R 20 160K	S	
385/65 R 22,5 158K		
315/80 R 22,5 156/150G		D
395/85 R 20 168G	S	
525/65 R 20,5 173F		S
16 00 R 20 173G	S	S
16 00 R 20 163G	S	
24 R 20,5 176F		S

S single

D double

Other tyres available, subject to the Astra technical office approval.



## PNEUMATIC SYSTEM

Two-cylinder 630 cc compressor , APU (Air Processing Unit) that includes: regulation valve set at 10.3 bar, drier, 4-way safety valve, pressure reduction valve for parking circuit and services. 3 air tanks, capacity 30 litres + 2 with 20 litres. ABS system and EBL (Electronic Brake Limiter)



## BRAKES

Front and rear "duo-duplex" self-adjusting wedge type brakes with automatic play take-up.

Total net braking surface 9.276 cm<sup>2</sup>.

ABS system.

**Service brake:** Pedal controlled air brake, acting on all wheels.

**Solo vehicles,** two independent circuits, one for 1<sup>st</sup> axle, one for 2<sup>nd</sup> and 3<sup>rd</sup> axle.

**Towing vehicles,** three independent circuits, one for 1<sup>st</sup> axle, one for 2<sup>nd</sup> and 3<sup>rd</sup> axle and another for the trailer.

**Emergency brake:** Incorporated in service brake.

**Parking brake:** Mechanical spring-type with pneumatic control acting on 2<sup>nd</sup> and 3<sup>rd</sup> axle wheels.

### IVECO BRAKE TURBO engine brake:

HD9 380/420 HP braking power 200 kW (272 HP)

HD9 440/480/540 HP braking power 255 kW (347 HP)

### On request:

Hydraulic intarder (HD9 66.38 and HD9 66.42 excluded). 1<sup>st</sup> axle immobiliser system.

OFF/ROAD button for excluding ABS for speed < 15 kph.

**HD9 380/420 cv** - Front and rear "simplex" self-adjusting

brakes system.

No ABS system.

No hydraulic intarder.





## ELECTRICAL SYSTEM

Voltage: 24 V  
 Alternator generator 90 A - 28 V (2520 W).  
 Accumulators: 2 in series, 143 Ah.  
 Starter motor 24 V 5,5 kW.  
 Mechanically controlled electrical circuit breaker.  
 1 electrical joint 7-pole(ISO 7638) for trailer ABS(if applicable).  
 1 electrical joints 15-pole(ISO 12089-4091) for trailer lighting (if applicable).  
 Electrical provision for bodybuilders.  
 Provision for diagnostics.  
 Provision for radio/cb (without speakers)  
 Glow plug for cold start.

### On request:

170 Ah accumulators;  
 143 Ah tropicalised accumulators;  
 170 Ah tropicalised accumulators;  
 Reverse alarm;



## CAB

White cab with hydraulic tipping. Built in steel. Tested on the most demanding off road routes. Cab suspension with guiding arms, 4 helicoidal springs, double action shock absorbers, anti-roll bar and end-of-stroke pads.  
 Internal panels completely washable and fireproof. 4-speed ventilation and heating system with air recirculation system.  
 Collapsible first step. Electric power windows on driver and passenger doors. Driver seat with pneumatic suspension and seat belt. Mechanical passenger seat with belts.  
 Tinted athermic windows.  
 Steering wheel adjustable in height and angle.

### On request:

Car radio RDS, CD;  
 Car radio RDS, CD, MP3, Blue Tooth technology;  
 Compressed air quick coupling for cab cleaning;  
 Roof hatch;  
 Air conditioning;  
 Centralized closing of the doors with remote control;  
 Extra colour cab: metallic / non-metallic;  
 Heated and electric powered rear view mirrors;  
 Cab rear window;  
 External sun visor.  
 Long cab for wheelbase >3800 mm with driver seat and passenger seat and 2 beds.  
 Long cab for wheelbase >3800 mm with interior equipment (seats and beds) on request.



## SERVICE DATA(I)

Engine oil sump and filters .....	28
Gearbox oil: ZF16S1820TO .....	11
Gearbox oil: ZF 16S2220TO/ZF 16S2520TO .....	13
Power steering oil .....	8,5
Cab tipping oil .....	1
Clutch circuit oil .....	0,5
Integral PTO oil .....	3
Intermediate axle with final red. oil .....	27
Rear axle with final red. oil .....	16
Cooling system water .....	33
Diesel .....	300



## INSTRUMENTATION

Dashboard and ergonomic instrument board contain the function buttons and the identification commands.

**Indicator lights:** engine oil low pressure, alternator charging low, main beam lights, side lights, engine warm-up, rear fog light, hazard lights, tractor turn indicators, trailer turn indicators (if applicable), rotating lights, cab lifted, axles differential locked, differential lock, front brakes air pressure low, rear brakes air pressure low, trailer brakes air pressure low (if applicable), parking brake engaged, splitter (reduction on), slow speeds (1-4/9-12), power take-off on (if applicable) air filters clogged, power steering oil level low, rear view mirrors heated (if applicable), ABS, trailer ABS (if applicable), main steering circuit failure, steering auxiliary circuit failure.

### ASTRA Veicoli Industriali

Via Caorsana, 79  
 29122 Piacenza (Italy)  
 Tel. ++39-523/5431  
 Fax ++39-523/59.17.73  
 www.astraspa.com

### DEALER

Characteristics and equipment are subject to changes without prior notice.



Technical data and general specifications - validity to be checked according to each individual country.