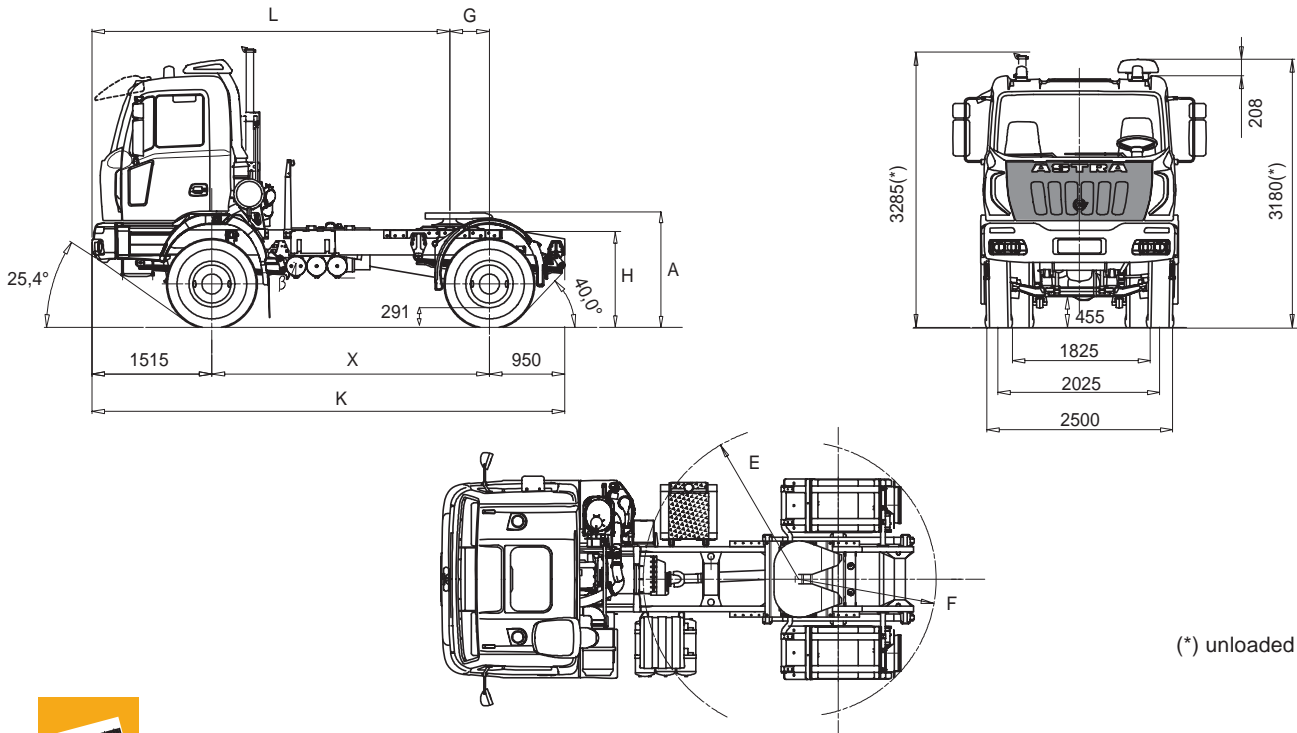

# H&DE

**tractor 4x2**
**42.31T / 42.38T / 42.42T / 42.44T / 42.48T**

(\*) unloaded

**DIMENSIONS (mm)** (Tyres 315/80R22.5 156/150K)

X	K	L		G		H		A(*)		E		F		TURNING DIAMETER
		min.	max.	min.	max.	unloaded	loaded	unloaded	loaded	front radius	rear radius	min.	max.	
3500	5965	5250	4988	715	977	1228	1116	1455	1343	1482	1744	1900	2113	12900
4200	6665	5888	5572	777	1093					2066	2382	1850	2211	13800

(\*) Fifth Wheel h 185 mm (opt)

**WEIGHT (kg)**

Distribution net weight (*)				Max. technical weight					
wheelbases	1 <sup>st</sup> axle	2 <sup>nd</sup> axle	net weight	1 <sup>st</sup> axle		2 <sup>nd</sup> axle	Fifth Wheel	Tractor	Gross Combination Weight
3500	5270	2370	7640	8000	8500	13000	13360	21000 (2)	55000
4200	5540	2170	7710		9000 (1)		13290		

(\*) Weight including oil, fuel, spare wheel, driver Kg.75

 (1) With tyres 1<sup>st</sup> axle 385/65R22,5 160J or 365/85R20164G. Other tyres available, subject to the Astra technical office approval.

(2) HD8 42.48T only at max speed 50 km/h. Michelin/Pirelli tyres. Higher speed/load are allowed with load/speed reductions subject to the Astra Technical office approval.



## ENGINES

CURSOR 8 F2B and CURSOR 13 F3B turbo intercooler euro 3 diesel injection/cycle with electronic unit injection pumps. 6 in-line cylinders. Single block head, four valves per cylinder, light alloy pistons. Total displacement: 7.790 cm<sup>3</sup> for F2B engines and 12.882 cm<sup>3</sup> for F3B engines. Bore for stroke: 115x125 mm for F2B and 135 x 150 mm F3B. Water cooling. Viscostatic cooling fan. Dry air filter with safety cartridge. Vertical muffler

	42.31T	42.38T	42.42T	42.44T	42.48T
Model	IVECO F2B	IVECO F3B	IVECO F3B	IVECO F3B	IVECO F3B
Max. power (EEC)	228 kW ( 310 HP)	280 kW (380 HP)	309 kW (420 HP)	324 kW (440 HP)	353 kW (480 HP)
Corresponding rpm	2.400	1.900			
Max. torque (EEC)	1.100 Nm (112 kgm)	1.800 Nm (184 kgm)	1.900 Nm (194 kgm)	2.100 Nm (214 kgm)	2.200 Nm (224 kgm)
Corresponding rpm	1.000-1.950	1.000-1.440			
Turbine	VGT variable geometry	WG Waste Gate		VGT variable geometry	



## GEARBOX

Manual gear **ZF 16 S 1620 TD** for HD8 42.31T and **ZF 16 S 2220 TO** for HD8 42.38T /HD8 42.42T / HD8 42.44T and **ZF 16 S 2520 TO** for HD8 42.48T - with servoshift, 16 synchronised forward speeds + 2 reverse.

		Speed [kph] at maximum power																		
		Gears																		
		1	2	3	4	5	6	7	8	9	10	11	12	13	14	15	16	RM	RM	
ZF 16 S 1620TD	Gear ratios	16,41	13,80	11,28	9,49	7,76	6,53	5,43	4,57	3,59	3,02	2,47	2,08	1,70	1,43	1,19	1,00	15,36	12,92	
	Rear axle ratio	1:3,793	6,0	7,1	8,7	10,4	12,7	15,1	18,2	21,6	27,5	32,7	39,9	47,4	58,0	69,0	82,9	98,6	6,4	7,6
		1:4,229	5,4	6,4	7,8	9,3	11,4	13,5	16,3	19,4	24,6	29,3	35,8	42,5	52,0	61,9	74,3	88,5	5,8	6,8
		1:5,009	4,6	5,4	6,6	7,9	9,6	11,4	13,8	16,3	20,8	24,7	30,2	35,9	43,9	52,2	62,8	74,7	4,9	5,8
		1:5,558	4,1	4,9	6,0	7,1	8,7	10,3	12,4	14,7	18,8	22,3	27,3	32,4	39,6	47,1	56,6	67,3	4,4	5,2
		1:6,095	3,7	4,4	5,4	6,5	7,9	9,4	11,3	13,4	17,1	20,3	24,9	29,5	36,1	42,9	51,6	61,4	4,0	4,8
		1:6,588	3,5	4,1	5,0	6,0	7,3	8,7	10,5	12,4	15,8	18,8	23,0	27,3	33,4	39,7	47,7	56,8	3,7	4,4
ZF 16 S 2220TO ZF 16 S 2520TO	Gear ratios	13,80	11,54	9,49	7,93	6,53	5,46	4,57	3,82	3,02	2,53	2,08	1,74	1,43	1,20	1,00	0,84	12,92	10,80	
	Rear axle ratio	1:3,793	7,1	8,5	10,4	12,4	15,1	18,1	21,6	25,8	32,7	39,0	47,4	56,7	69,0	82,2	98,6	117,4	7,6	9,1
		1:4,229	6,4	7,7	9,3	11,2	13,5	16,2	19,4	23,2	29,3	35,0	42,5	50,8	61,9	73,7	88,5	105,3	6,8	8,2
		1:5,009	5,4	6,5	7,9	9,4	11,4	13,7	16,3	19,6	24,7	29,5	35,9	42,9	52,2	62,2	74,7	88,9	5,8	6,9
		1:5,558	4,9	5,8	7,1	8,5	10,3	12,3	14,7	17,6	22,3	26,6	32,4	38,7	47,1	56,1	67,3	80,1	5,2	6,2
		1:6,095	4,4	5,3	6,5	7,7	9,4	11,2	13,4	16,1	20,3	24,3	29,5	35,3	42,9	51,2	61,4	73,1	4,8	5,7
		1:6,588	4,1	4,9	6,0	7,2	8,7	10,4	12,4	14,9	18,8	22,4	27,3	32,6	39,7	47,3	56,8	67,6	4,4	5,3



## P.T.O.

On request:

Gearbox	ZF16S1620TD	ZF16S2220TO-ZF16S2520TO	Max. torque	Application
P.T.O.	Ratio	Ratio	Nm.	
ZF NH/1b	0,77/0,91:1	0,91/1,09:1	1000	For tipping unit pumps, pumps for cranes, ecc..
ZF NH/1c	0,77/0,91:1	0,91/1,09:1	1000	For tipping unit pumps, unit pumps for concrete, pumps for cranes, ecc..
ZF NH/4c	0,98/1,17:1	1,17/1,40:1	430	For tipping unit pumps, ecc..
ZFN221/10bpl+N353/1c		1,75/2,09:1+0,91/1,09:1	560+600	double PTO for concrete pumps

Power take off at flywheel (ratio 1,29:1) max available torque 900 Nm for concrete mixers.



## CLUTCH

Single dry plate, diameter 17". Pull type engagement with diaphragm spring. Hydro-pneumatic power steering engagement control, with driven disk wear recovery slave cylinder.

Technical data and general specifications - validity to be checked according to each individual country.



## AXLES

### FRONT

Steering, hot moulding in high tensile steel. Wheel stud protection.

### REAR

engine axle with dual reduction, central with bevel gear pair, final in wheel hubs by means of epicycloidal assembly .

Lockable differential with pneumatic control from driver's seat.

#### On request:

Rear-axle ratio 1:3,793  
Rear-axle ratio 1:4,229  
Rear-axle ratio 1:5,009  
Rear-axle ratio 1:5,558  
Rear-axle ratio 1:6,095  
Rear-axle ratio 1:6,588



## SUSPENSIONS

### FRONT

Parabolic leaf springs with bushings, n° 4 leaves 24x90 mm, with shock absorbers and stabilizer bar.

#### On request:

Reinforced parabolic springs, n° 5 leaves 24x90 mm.  
Extra-reinforced conventional springs, n° 10 leaves 15x90 mm.

### REAR

Parabolic springs with bushings, n° 4 leaves 24x90 mm, + 1 leaf 50x90 mm, with shock absorbers and stabilizer bar.



## CHASSIS

Special steel with high elasticity limit, two flat and parallel side members width 820 mm., C section 320x70x8 mm, cross members riveted to the frame.

Steel front bumpers with headlamp protection grids, front manoeuvring hook, rear underrun bar, steel fuel tank capacity 300 litres. Fifth wheel helper frame, spot and side alighting step. rubber mudguards on 2<sup>nd</sup>, toolbox, side winch for spare wheel.

#### On request:

Rapid attachment for compressed air for tyres'inflation.  
Rear manoeuvring hook.  
Fixed 2" fifth wheel h 150.  
Fixed 2" fifth wheel h 185.  
Front bumper climbing step.



## PNEUMATIC SYSTEM

Two-cylinder 630 cc compressor , APU (Air Processing Unit) that includes: regulation valve set at 10.3 bar, drier, 4-way safety valve, pressure reduction valve for parking circuit and services. 3 air tanks, capacity 30 litres + 2 with 20 litres. ABS system and EBL (Electronic Brake Limiter)



## STEERING

ZF 8098 hydraulic power steering on front axle wheels with variable ratio 1:22.2/1:26.2.

Circuit with main hydraulic pump on engine and emergency pump on gearbox. Steering rods with self-lubricating joints. Height and inclination mechanically adjustable steering wheel.



## TYRES

**FRONT:** 315/80R22,5 156/150 K Single tubeless

**REAR:** 315/80R22,5 156/150 K Twin tubeless

Spare wheel on the chassis.

#### Other Possible combinations:

TYRES	ASSEMBLY	
	FRONT	REAR
13 R 22,5 156/150G	S	D
12 00 R 20 156/150G		
385/65 R 22,5 160J*	S	
315/80 R 22,5 156/150K		D

**S** single

**D** double

Other tyres available, subject to the Astra technical office approval.

\* Mandatory with 9t front axle load.



## BRAKES

Front and rear "duo-duplex" self-adjusting wedge type brakes with automatic play take-up.

Total net braking surface 6.184 cm<sup>2</sup>.

ABS system.

**Service brake:** Pedal controlled air brake, acting on all wheels, three independent circuits, one for 1<sup>st</sup> axle, one for 2<sup>nd</sup> axle and another for the trailer.

**Emergency brake:** Incorporated in service brake.

**Parking brake:** Manual spring-type mechanical with pneumatic control acting on 2<sup>nd</sup> axle wheels.

**IVECO BRAKE TURBO engine brake:**

HD8 310 HP braking power 170 kW (231 HP)

HD8 380/420/440/480 HP braking power 255 kW (347 HP)

#### On request:

Hydraulic interarder (HD8 42.31T excluded).

1<sup>st</sup> axle immobiliser system.

OFF/ROAD button for excluding ABS for speed < 15 kph.



## ELECTRICAL SYSTEM

Voltage: 24 V

Alternator generator 90 A - 28 V (2520 W).

Accumulators: 2 in series, 143 Ah.

Starter motor 24 V 5,5 kW.

Mechanically controlled electrical circuit breaker.

Phonic wheels and sensors on 1<sup>st</sup> and 2<sup>nd</sup> axle.

1 electrical joint 7-pole(ISO 7638) for semi-trailer ABS.

1 electrical joints 15-pole(ISO 12089-4091) for semi-trailer lighting.

Electrical provision for outfitters.

Provision for diagnostics.

Provision for radio/cb (without speakers)

Glow plug for cold start.

#### On request:

143 Ah tropicalised accumulators;

170 Ah accumulators;

170 Ah tropicalised accumulators;

220 Ah accumulators;

Reverse alarm;

Electric main current cut-off switch.





## CAB

White cab with hydraulic tipping. Built in moulding fiberglass with tubular steel armature. Tested on the most demanding off road routes. Cab suspension with guiding arms, 4 helicoidal springs, double action shock absorbers, anti-roll bar and end-of-stroke pads. Internal panels completely washable and fireproof. 4-speed ventilation and heating system with air recirculation system.

Collapsible first step. Electric power windows on driver and passenger doors. Driver seat with pneumatic suspension and seat belt. Mechanical passenger seat with belts. Tinted athermic windows. Steering wheel adjustable in height and angle.

### On request:

Car radio RDS, CD;  
Car radio RDS, CD, MP3, Blue Tooth technology;  
Compressed air quick coupling for cab cleaning;  
Roof hatch;  
Air conditioning;  
Centralized closing of the doors with remote control;  
Extra colour cab: metallic / non-metallic;  
Heated and electric powered rear view mirrors;  
Cab rear window;  
External sun visor.



## SERVICE DATA(I)

Engine oil sump and filters .....	28
Gearbox oil ZF16S1620TD: .....	11
Gearbox oil ZF16S2220TO/ZF16S2520TO: .....	13
Power steering oil .....	8,5
Cab tipping oil .....	1
Clutch circuit oil .....	0,5
Rear axle with final red. oil .....	16
Cooling system water .....	33
Diesel .....	300



## INSTRUMENTATION

Dashboard and ergonomic instrument board contain the function buttons and the identification commands.

**Indicator lights:** engine oil low pressure, alternator charging low, main beam lights, side lights, engine warm-up, rear fog light, hazard lights, tractor turn indicators, semi-trailer turn indicators, rotating lights, cab lifted, axles differential locked, differential lock, front brakes air pressure low, rear brakes air pressure low, semi-trailer brakes air pressure low, parking brake engaged, splitter (reduction on), slow speeds (1-4/9-12), power take-off on (if applicable) air filters clogged, power steering oil level low, rear view mirrors heated (if applicable), ABS, semi-trailer ABS, main steering circuit failure, steering auxiliary circuit failure.

### ASTRA Veicoli Industriali

Via Caorsana, 79  
29100 Piacenza (Italy)  
Tel. ++39-523/5431  
Fax ++39-523/59.17.73  
www.astraspa.com

### DEALER

Characteristics and equipment are subject to changes without prior notice.



Technical data and general specifications - validity to be checked according to each individual country.